

- Input voltage: DC 7.4V 2cell Lithium battery
- Output voltage: DC 5.8V
- Max. Continuous Current: 3A
- Integrated power switch and voltage indicator meter
- 5.1V Step-Down Voltage Regulator
- Utilizes a linear design, resulting in no interference to the receiver.
- Size: 60x25x6mm
- Weight: 15g(including wire set)

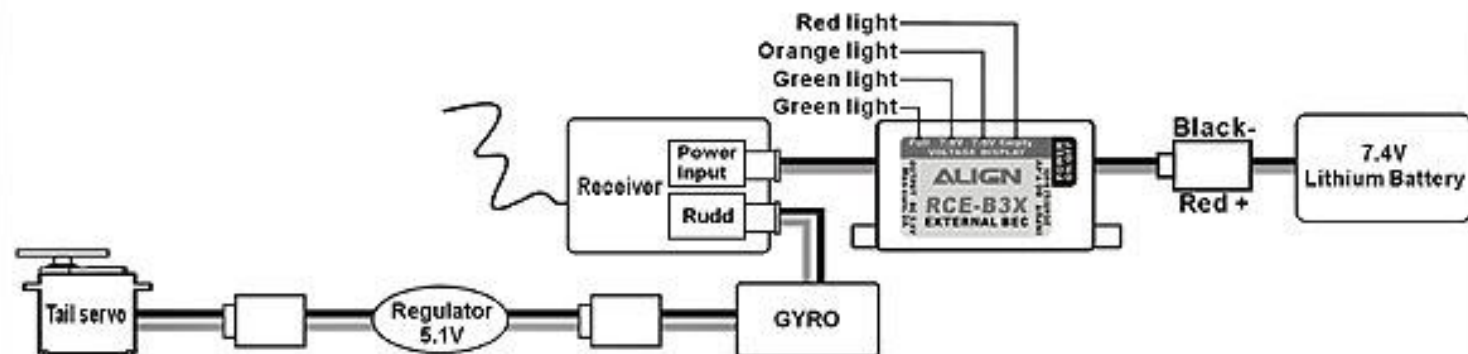

#### Instruction:

1. Auto-detecting voltage meter display lights. If the entire four-light array is illuminated, the battery is fully charged. When the voltage drops below 7.6V, the two green lights will be turned off. Use caution, the battery can only be safely used for a single flight. When only the red light is on, the battery voltage is drained, and must be fully recharged before use. Do not attempt to operate the model during this condition!
2. Includes a 5.1V Step-Down Voltage Regulator, allowing use of Futaba servo models 9241,9251,9253,9254,9255,9256, and other digital servos not capable of handling 6V. Connect the regulator inline between the Gyro and the rudder servo (see illustration). If you are using a servo that can accept 6V input, the regulator is not required.
3. When using a speed controller with BEC output, you must remove the red wire of BEC output on the speed controller.
4. If the receiver does not have enough channels or an available socket, you can use a Y-type servo harness to share any channel with an existing connection.